

# DIONYSOS

High quality GRAPE sorter  
with capacity from 10 to 15 Tn/h



The first 3 WAY  
sorting machine  
in wine



Top quality wine accept just sound and ripe grapes. The new multi-frequency sorter DIONYSOS automatically removes all contaminants from the inlet stream and ensure the top quality grapes to the wine process, up to a capacity from 10 to 15 Tn/h.



## TECHNOLOGIES

### BLUEIGHT

Illuminator multifrequency pulsed LED light; eight on-board functions in a single sorter to overcome the limits of the laser.



The new board image processing, even more powerful, compact and reliable that integrates the automation of machine: all in one case.

Powered by the **BLUEIGHT** technology it removes all contaminants such as:

- rotten grapes, even if they have the same color of the good ones
- stalks, leaves and, if requested, green grapes
- any type of plastic, irrespective of the color
- any kind of insect
- dry grapes

By the Double Rejection System (air jet + air jet) the **DIONYSOS** can be configured as a **3WAY** sorter, to reject on a separate stream the dry grapes, usually addressed to 2nd quality wines. Avoiding the 2nd late fermentation due to the dry grapes this sorter helps in keeping the sugar level under control.

## DETAILS



PH Reject 2

STEM Reject 1

DRY Reject 2

GOOD

GREEN Reject 1



Reject 1

## ADVANTAGES



CIT



CHLOROPHYLL



HSL



SHAPE



BLOB



BIG STOP



GLASS

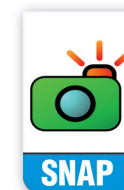

SNAP



STEM



WWW.RAYTECVISION.COM

Innovation in Sorting Equipment

# BLUEIGHT

## WHAT IS THE BLUEIGHT TECHNOLOGY?

It is a package of functions based on 8 different processed images obtained by pulsing in a sequence different lights. By this technology it won't be necessary to install a different color belt to identify the items, or to sort them by flying on rotating luminous backgrounds.

### IT WILL BE POSSIBLE TO:

- capture images directly by the stream and check the adjustment's results by the graphic interface
- analyze the defects by means of HSL color analysis
- check the chlorophyll content
- rejected by size (BLOB) and shape
- stop the machine in case of animal detection (or a part of it)
- detect transparent glass or plastic
- reject grapes with stem

# SMART-JET

For outstanding quality results it is necessary to guarantee not just a perfect sorting adjustment, but also a perfect rejection activity. The **DIONYSOS**, equipped with the **SMART-JET** driver card, makes sure that the array of 112+112 high speed valves, will be perfectly operational not only electrically, but also pneumatically.

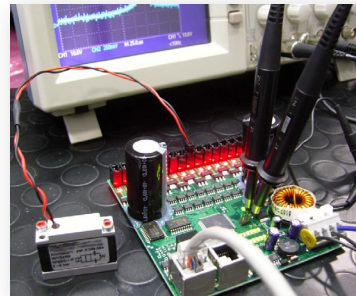

Driver card SMART-JET

# 3WAY OPTION

**DIONYSOS** can be equipped with single or double rejection system, Air-jet+Ari-Jet.

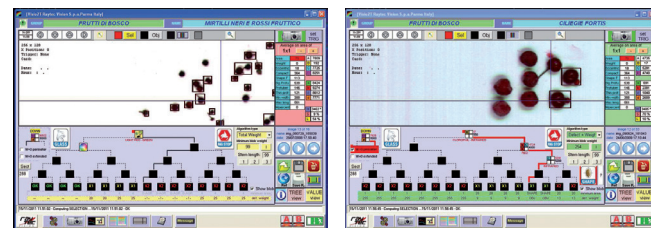

Adjustments are performed on the machine monitor checking directly on the product image if the reject threshold is effective.



3WAY rejection system

# DIONYSOS

makia.it

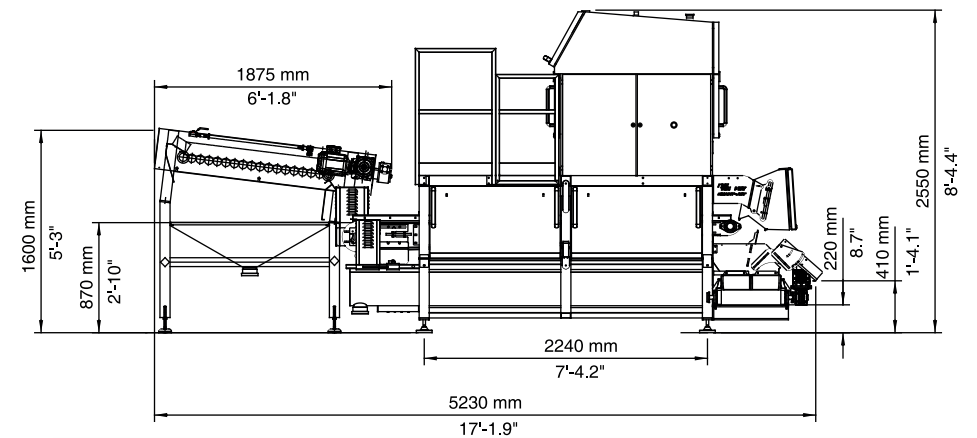
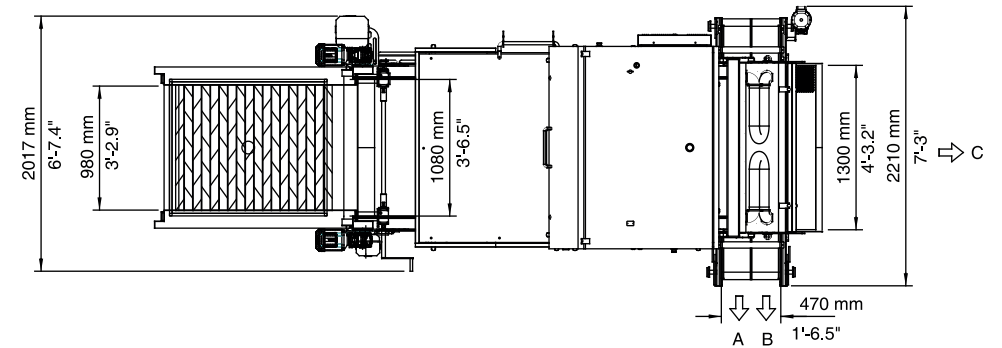

## TECHNICAL FEATURES

Sorting efficiency - organic defects	95%
Sorting efficiency - non-organic defects	97%
Sorting efficiency - dry grapes (also on 3WAY configuration)	85 %
Optical resolution	0.5 mm
Reject channels	112+112
Reject channel pitch	9 mm
Sorting conveyor speed	100-160 m/min
Sorting conveyor width	1081 mm
Weight	1700 kg

[WWW.RAYTECVISION.COM](http://WWW.RAYTECVISION.COM)

RAYTEC Spa Via Paradigna 94/a - 43122 Parma - Italy  
Tel. + 39 0521.303427 Fax +39 0521.339325 - info@raytecvision.com

